



Datasheet

Wallbox 7.4kW 32A Air

Part No: 100536

About the product

The Loxone Wallbox is a charging station which enables dynamic charging from 1.38kW to 7.4kW for electric vehicles. With the robust Air interface, the device is integrated into the Loxone system and provides all the freedom for energy management. To record the electrical energy, an energy meter can be easily mounted on the integrated DIN-rail and connected to the Modbus interface in the device. Optionally, products like the NFC Code Touch, Touch Pure Flex,... can be mounted directly on the device to set your charging mode or execute any other control.

Electrical Data

Supply and Power	AC Input (mains)	24V DC Output
Rated voltage	1x 230V, 50-60Hz	24V DC
Rated current	1x 32A	max. 100mA
Power consumption	Standby: 0.6W, charging: 2.5W	-

A 30mA type A RCD must be connected before each wallbox!

Charging

Max. charging power	7.4kW (32A) configurable from 1.38kW to 7.4kW
Charging Mode	Charging mode 3 (IEC 61851-1)
Residual current detection	Internal, RDC-MD, DC 6mA (IEC 62955)
Charging cable with plug	Type 2 plug (IEC 62196) 5 meter cable, 3x6mm ² + 1x0.5mm ²

Interfaces

Loxone Air	connection with Miniserver / Air Base Extension 868MHz (SRD Band Europe), 4 channels, max. 15.1mW e.r.p. 915MHz (ISM Band Region 2), 10 channels, max. 13.2mW Internal antenna
Modbus RTU for connecting Energy meters	max. 1 device max. 3m wire length adjustable baud rate & parity data types: 16 & 32 bit min. polling cycle: 5s
Loxone Tree	Prepared for connecting Tree devices Available via firmware update in 2024

Ambient conditions

Ambient temperature	-20...50°C / -4...122°F
Ambient humidity	max. 95% r.H. (non condensing)
Degree of Protection	IP44 (IEC 60529) IK08 (IEC 62262)
Appliance class	Class I
Installation	Stationary, surface mount, vertical on wall or charging post
Recommended mounting height	Cable outlet: 132cm / 52" Top edge: 165cm / 65"
Altitude	max. 2000m

Connecting Terminals

	AC Input	Charging Output	DC Output, Loxone Tree	Modbus
Terminal type	DG2216V	DG2206V	DG220B	SPTAF 1
Wire cross-section	0.5 ... 16mm ² / AWG 20 ... 5	0.5 ... 6mm ² / AWG 20 ... 8	0.28 ... 0.8mm ² / AWG 23 ... 18	0.25 ... 0.75mm ² / AWG 24 ... 16
Stripping length	12mm / 0.47"	12mm / 0.47"	5 ... 6mm / 0.2 ... 0.24"	8mm / 0.31"
Temperature resistance	-40 ... 105°C / -40 ... 221°F	-40 ... 105°C / -40 ... 221°F	-40 ... 105°C / -40 ... 221°F	-60 ... 100°C / -76 ... 212°F
Terminal compartment	DIN Rail with 158mm / 6.2" width, room for devices with up to 9 division/breaker units			

Connection Diagram

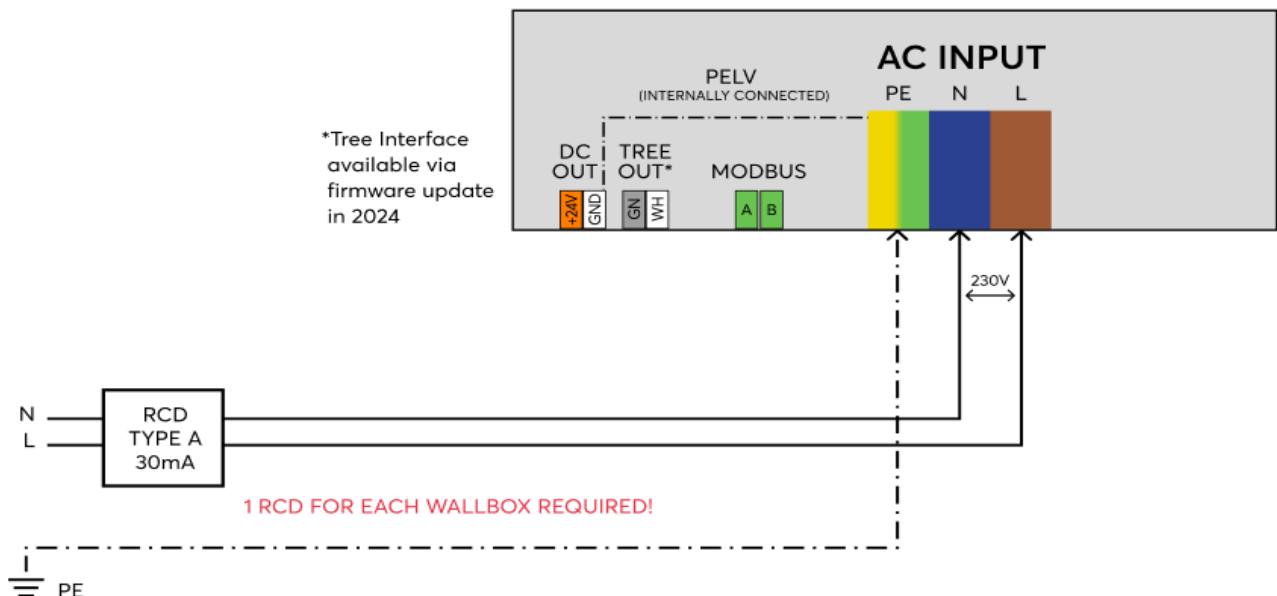

Product Characteristics

Colours	Housing: RAL 9005 Decor cover: RAL 9003
Finish	Matte

Weight & Dimensions

Net weight	3,5kg
Total weight	4,8kg
Product dimensions	430x190x130mm / 16.93x7.48x5.12" (HxWxD)

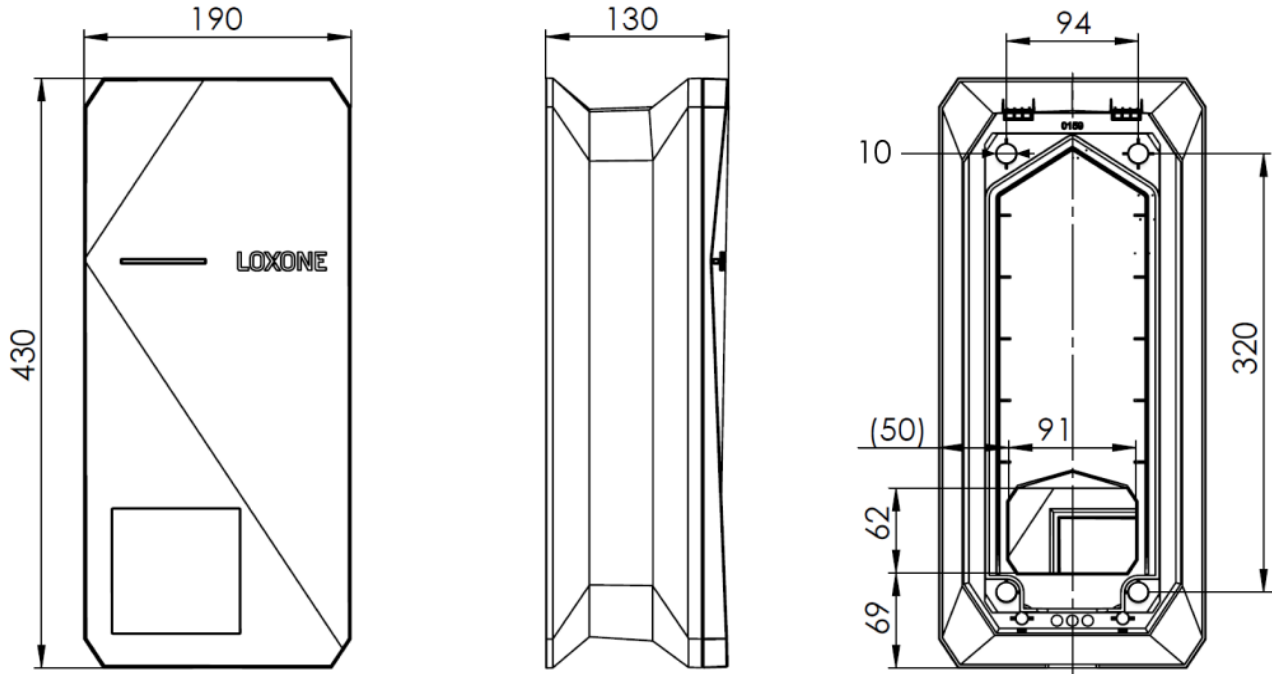

Pack size	575x330x155mm / 22.64x12.99x6.1" (HxWxD)
-----------	--

Certifications & Standards

Degree of pollution	3
Standards	CE (LVD 2014/35/EU, EMC 2014/0/EU) IEC 61851-1 IEC 61851-22
Certifications	

Installation must be carried out by a qualified electrician in accordance with the relevant regulations.

Published by

Loxone Electronics GmbH

Smart Home 1
4154 Kollerschlag
Austria
Tel: +43 7287 7070-0
loxone.com

Loxone UK

The Forum
Station Road
Theale, RG7 4RA
United Kingdom



Datenblatt

Wallbox 7,4kW 32A Air

Art. Nr. 100536

Information zum Produkt

Die Loxone Wallbox ist eine Ladestation, die dynamisches Laden von 1,38kW bis 7,4kW für Elektrofahrzeuge ermöglicht. Mit der robusten Air Schnittstelle wird das Gerät in das Loxone-System integriert, und bietet alle Freiheiten für das Energiemanagement. Zur Erfassung der elektrischen Energie kann ein Energiezähler einfach auf der integrierten Hutschiene montiert und an die Modbus-Schnittstelle im Gerät angeschlossen werden. Optional können Produkte wie der NFC Code Touch, Touch Pure Flex,... direkt am Gerät montiert werden, um Ihren Lademodus einzustellen oder andere Funktionen auszuführen.

Elektrische Daten

Versorgung und Leistung	AC Eingang (Netzspannung)	24V DC Ausgang
Nennspannung	1x230V, 50-60Hz	24V DC
Nennstrom	1x 32A	max. 100mA
Leistungsaufnahme	Standby: 0,6W, Laden: 2,5W	-

Jeder Wallbox muss ein 30mA Typ A Fehlerstrom-Schutzschalter (RCD) vorgeschaltet werden.

Laden

Max. Ladeleistung	7,4kW (32A) einstellbar von 1,38kW bis 7,4kW
Ladebetriebsart	Ladebetriebsart 3 (IEC 61851-1)
Fehlerstromerkennung	Intern, RDC-MD, DC 6mA (IEC 62955)
Ladekabel mit Stecker	Typ 2 Stecker (IEC 62196) 5 Meter Kabel, 3x6mm ² + 1x0,5mm ²

Schnittstellen

Loxone Air	Verbindung zu Miniserver / Air Base Extension 868MHz (SRD Band Europe), 4 channels, max. 15.1mW e.r.p. 915MHz (ISM Band Region 2), 10 channels, max. 13.2mW Interne Antenne
Modbus RTU zum Anschluss von Energiezählern	max. 1 Gerät max. 3m Leitungslänge einstellbare Baudrate & Parität Datentypen: 16 & 32 bit min. Abfragezyklus: 5s
Loxone Tree	Vorbereitet zum Anschließen von Tree Geräten Verfügbar ab 2024 durch Firmware Update

Umgebungsbedingungen

Umgebungstemperatur	-20...50°C / -4...122°F
Luftfeuchtigkeit	max. 95% r.H. (nicht kondensierend)
Schutzart	IP44 (IEC 60529) IK08 (IEC 62262)
Schutzklasse	Klasse I
Installation	Ortsfest, Aufbaumontage, vertikal an Wand oder Ladesäule
Empfohlene Montagehöhe	Kabelausschuss: 132cm / 52" Oberkante: 165cm / 65"
Seehöhe	max. 2000m

Anschlussklemmen

	AC Eingang	Ladeausgang	DC Ausgang, Loxone Tree	Modbus
Klemmentyp	DG2216V	DG2206V	DG220B	SPTAF 1
Leiterquerschnitt	0,5 ... 16mm ² / AWG 20 ... 5	0,5 ... 6mm ² / AWG 20 ... 8	0,28 ... 0,8mm ² / AWG 23 ... 18	0,25 ... 0,75mm ² / AWG 24 ... 16
Abisolierlänge	12mm / 0,47"	12mm / 0,47"	5 ... 6mm / 0.2 ... 0.24"	8mm / 0,31"
Temperaturbeständigkeit	-40 ... 105°C / -40 ... 221°F	-40 ... 105°C / -40 ... 221°F	-40 ... 105°C / -40 ... 221°F	-60 ... 100°C / -76 ... 212°F
Anschlussraum	Hutschiene mit 158mm / 6,2" Breite, Platz für Geräte mit bis zu 9 Teilungseinheiten			

Anschlussplan

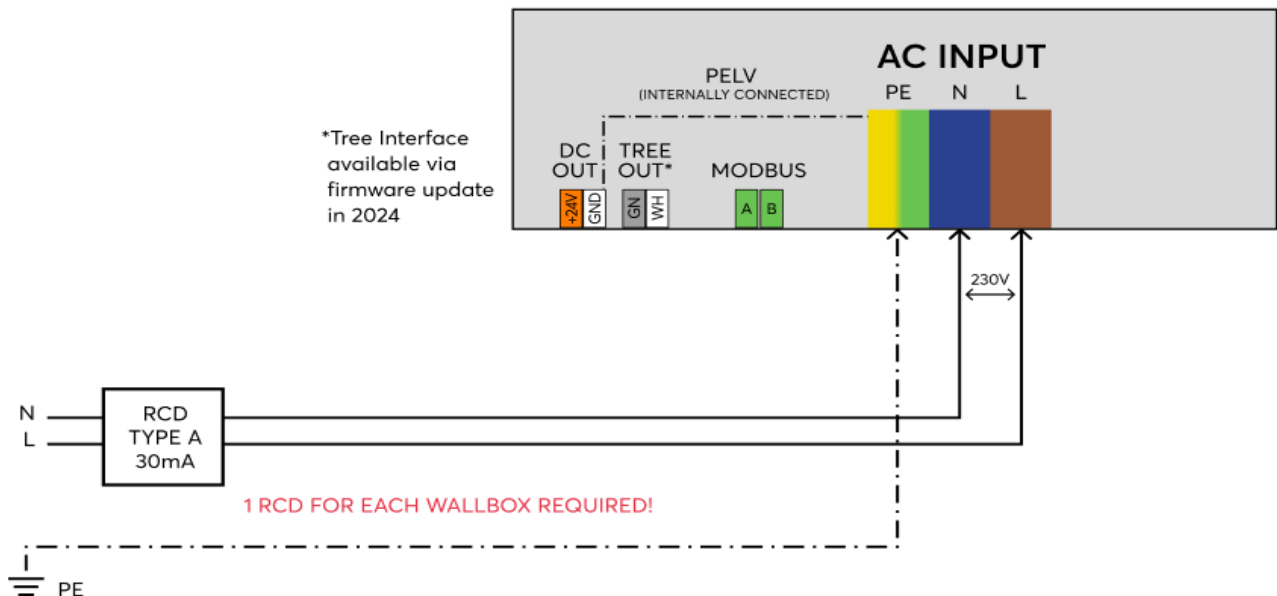

Produkteigenschaften

Farbe	Gehäuse: RAL 9005 Dekorabdeckung: RAL 9003
Glanzgrad	Matt

Gewicht & Abmessungen

Nettogewicht	3,5kg
Bruttogewicht	4,8kg
Produktmaße	430x190x130mm / 16,93x7,48x5,12" (HxBxT)

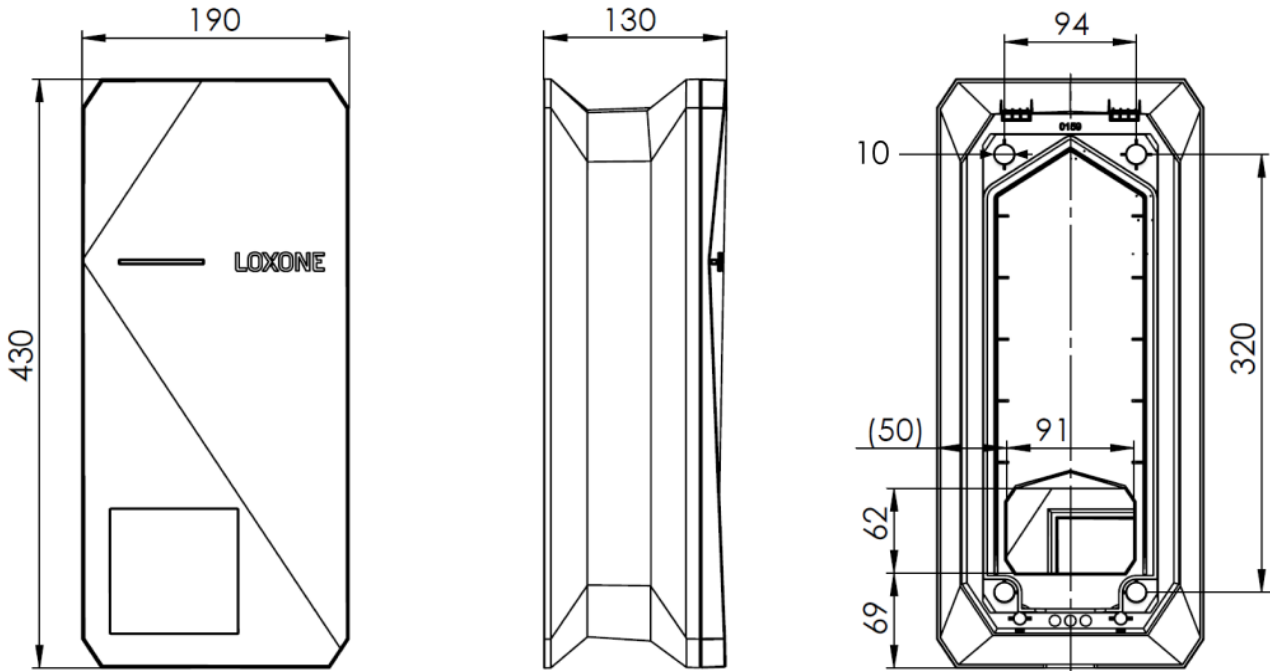

Packmaß	575x330x155mm / 22,64x12,99x6,1" (HxBxT)
---------	--

Zertifizierungen & Normen

Verschmutzungsgrad	3
Normen	CE (LVD 2014/35/EU, EMCD 2014/0/EU) IEC 61851-1 IEC 61851-22
Zertifizierungen	

Die Installation muss nach den einschlägigen Vorschriften durch eine Elektrofachkraft erfolgen.

Published by

Loxone Electronics GmbH

Smart Home 1
4154 Kollerschlag
Austria
Tel: +43 7287 7070-0
loxone.com

Loxone UK

The Forum
Station Road
Theale, RG7 4RA
United Kingdom